

# BUGQUEST

## Instruction Manual – School

### Contact:

[bugquest.canada@gmail.com](mailto:bugquest.canada@gmail.com)

519-824-4120 x58259



### Shipping details:

Ross Stewart  
Centre for Biodiversity Genomics  
University of Guelph  
50 Stone Road East  
Guelph, ON N1G 2W1

DNA  'em all!

# Overview

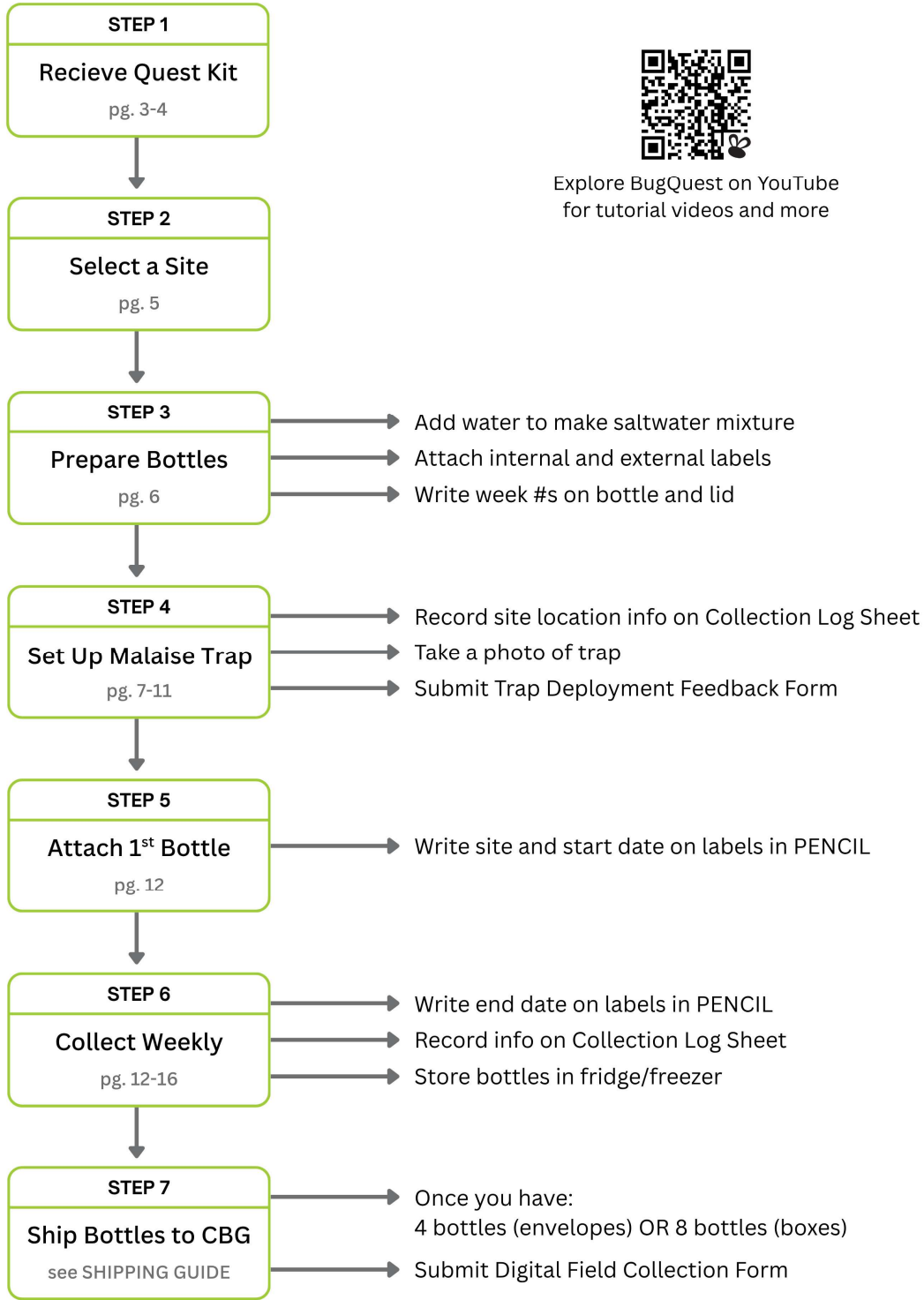

# Welcome to BugQuest!

This manual contains everything you need to successfully complete your BugQuest! Inside, you will find step-by-step instructions for setting up your trap, collecting your insects, and returning your bottles so they can be DNA barcoded. By following these instructions, you and other participants across Canada will help us learn more about our national insect biodiversity while making the most out of your BugQuest experience.

## Quest Kit Contents:



- **Instruction Manual**
  - General Timeline & Key Dates
  - Site Selection Guide
  - Preparation Guide
  - Trap Set-up Guide
  - Collection Guide
  - Shipping Guide
- **Malaise Trap Kit**
  - 1 Malaise trap tent
  - 1 long tent pole
  - 1 short tent pole
  - 9 support ropes
  - 16 metal tent pegs
  - 1 trap carrying bag
- **Collection Equipment**
  - Collection bottles, pre-filled with table salt, 1 per week
  - External sticker labels
  - Internal paper labels
  - Collection Log Sheets
  - Pencils
  - Flagging tape
  - Reusable cable ties
  - BugQuest: Science in Progress* sign
- **Return Shipping Materials**
  - Return shipping labels
  - Shipping boxes and/or envelopes
  - BugQuest address stickers
  - Large plastic bags

## What you'll need:

- Tap water
- Marker
- Tape
- Freezer or refrigerator
- Paper towel (or other absorbent material)

## General Timeline & Key Dates

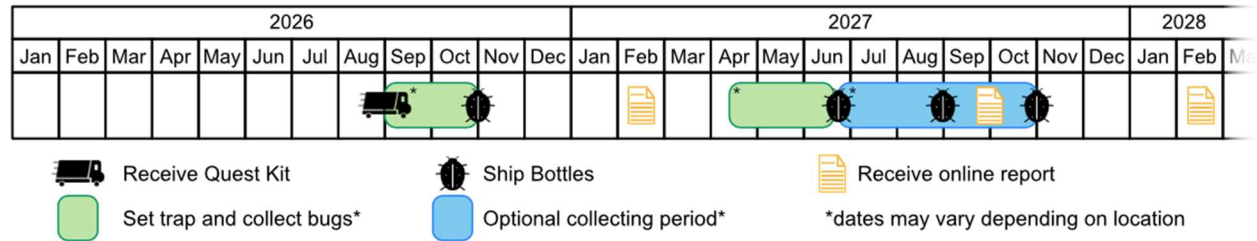

### Key Dates

#### Fall 2026

- **Receive Quest kit, set-up trap, and begin collections:** Early September
  - *Deadline to begin collections: **September 25, 2026***
- **Weekly bottle collections:** September-October
- **Ship bottles back:** End of October
  - *Deadline to ship collection bottles: **November 06, 2026***
- **After final collection:** Pack up the trap and store the Quest Kit until Spring

#### Spring 2027

- **Set-up trap and begin collections:** April-May
  - Trap set-up is determined by local temperatures (daytime temp above 10°C).
  - *Deadline to begin collections: **May 28, 2027***
- **Weekly bottle collections:** April-June
- **Ship bottles back:** end of June
  - *Deadline to ship collection bottles: **July 02, 2027***
- **After final collection,** you have the following options:
  1. Pack up the trap and return the Quest Kit to the BugQuest Team (you may include the last collection bottles in this shipment)
  2. Pack up the trap and store the Quest Kit until Fall 2027 to restart the collection
  3. Continue collecting throughout the summer (trap can be relocated)

# Site Selection Guide: Where Should Your Trap Go?

Once your Quest Kit arrives, it's time to become an insect explorer! One of the most important steps in BugQuest is choosing the right place to set up your Malaise trap. Where you place your trap will affect what insects you collect, so take time to explore and choose wisely.

**💡 Quest Tip** – Make sure you have all the proper permissions/collecting permits to set up the trap in the property you're considering (i.e. from landowners, site managers, etc.)

Before setting up, walk around your community, schoolyard, or natural area and look for different habitats. You might be surprised by how many ecosystems are nearby! This is a great opportunity to observe nature, map habitats, and think about how people and wildlife share the environment.

## Accessibility: Easy to Reach, Safe to Stay

Your trap needs to be checked at least once a week, so choose a spot that is easy to access and safe to visit regularly. Ensure it will not be in the way of community activities or landscaping maintenance.

Community interest in the trap is a very important part of BugQuest. However, consider the risk of accidental disturbance or vandalism. If this is a concern, an alternative secure location – such as a participant's private property – may be used, as long as it meets program requirements.

## Environment: Think Like an Insect

Now look closely at the habitat around your chosen spot. Insects are more active in certain areas, and your local knowledge will help you decide what's best. Great places for a Malaise trap include the edge of a wooded area, near a stream, or beside a garden.

Your trap will work best when placed on flat ground with short plants around it. Tall grass or thick vegetation near the trap opening can block insects from flying in, which means fewer insects to study.

## Trap positioning: Catching the Insect "Highway"

Insects often move along natural "flight pathways", such as open corridors in vegetation or animal trails. Invite participants to look for these pathways and think about how insects travel through their environment.

Position the trap so that the middle mesh panel blocks the flight path, guiding insects upward into the collection bottle. By thoughtfully selecting your site and positioning your Malaise trap, you will be working together to support meaningful insect collection while building skills in observation, inquiry, and environmental stewardship.

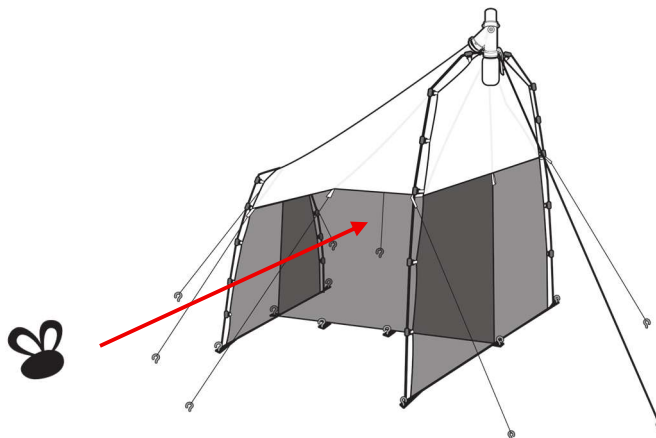

# Preparation Guide

## What you'll need:

- Collection bottles (pre-filled with table salt)
- External sticker labels
- Internal paper labels
- Pencil
- Marker
- Tap water (~300mL/bottle)

## Bottle preparation:

The saltwater mixture will help preserve the DNA from the insects.

1. Make a saltwater mixture by adding ~300mL of tap water to a collection bottle (~300mL=10cm/4 inches). Use the measurements on the side of this page for reference. Close the lid tightly and shake for 30 seconds to dissolve the salt. Some salt may remain undissolved.

2. Cut out individual **internal paper labels**. Labels are provided in batches of five, so you may have more labels than bottles.

 **Quest Tip** – Internal paper labels are printed on special fluid paper that is weather-resistant and waterproof.

3. Attach the **external sticker label** to the bottle with the matching **internal paper label** slid slightly underneath (see the image below). The internal paper label will later be placed inside the bottle. Make sure the BQ# on both labels are the same.



### External Sticker Labels

**BUGQuest** Store sample at -20°C!

Sample # BQ#00003

Collector: \_\_\_\_\_

Dates: \_\_\_\_\_ - \_\_\_\_\_

Province: \_\_\_\_\_

Site name: \_\_\_\_\_

Notes: \_\_\_\_\_

Lat: \_\_\_\_\_

Lon: \_\_\_\_\_

Elev: \_\_\_\_\_

**BUGQuest** Store sample at -20°C!

Sample # BQ#00004

Collector: \_\_\_\_\_

Dates: \_\_\_\_\_ - \_\_\_\_\_

Province: \_\_\_\_\_

Site name: \_\_\_\_\_

Notes: \_\_\_\_\_

Lat: \_\_\_\_\_

Lon: \_\_\_\_\_

Elev: \_\_\_\_\_

**BUGQuest** Store sample at -20°C!

Sample # BQ#00005

Collector: \_\_\_\_\_

Dates: \_\_\_\_\_ - \_\_\_\_\_

Province: \_\_\_\_\_

Site name: \_\_\_\_\_

Notes: \_\_\_\_\_

Lat: \_\_\_\_\_

Lon: \_\_\_\_\_

Elev: \_\_\_\_\_

### Internal Paper Labels

Sample # BQ#00003

Dates: \_\_\_\_\_ - \_\_\_\_\_

Site name: \_\_\_\_\_

Notes: \_\_\_\_\_

Sample # BQ#00004

Dates: \_\_\_\_\_ - \_\_\_\_\_

Site name: \_\_\_\_\_

Notes: \_\_\_\_\_

Sample # BQ#00005

Dates: \_\_\_\_\_ - \_\_\_\_\_

Site name: \_\_\_\_\_

Notes: \_\_\_\_\_



4. Find the bottle with the lowest BQ# and, using a permanent marker, write "week #1" on the lid and above the **external sticker label**. Leave the label blank – it will be filled out in **PENCIL** later.
5. Repeat steps 1 to 4 for the rest of the bottles, from lowest to highest BQ#, assigning week #2, week #3, etc...
6. Store prepared bottles away from the sunlight until they are needed.

# Trap Set-Up Guide

## What you'll need:

- Malaise trap kit
- Flagging tape
- BugQuest: Science in Progress* sign
- Reusable cable ties
- Collection Log Sheet
- Prepared collection bottle – external and internal labels attached and filled with saltwater mixture

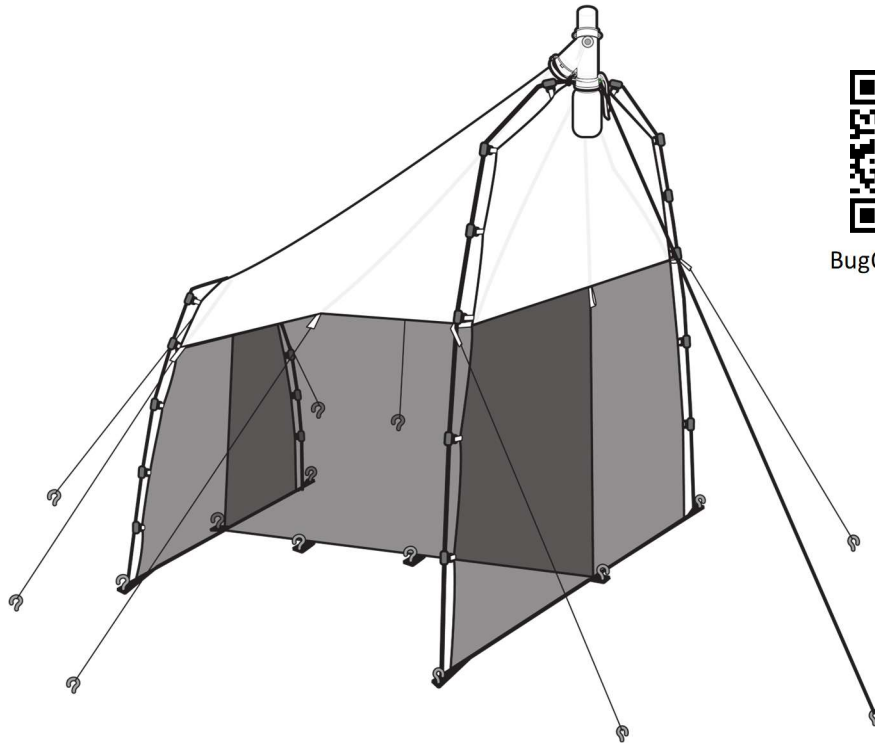

BugQuest YouTube

## Before you set-up the trap:

1. Watch our Trap Set Up Video on our BugQuest YouTube Playlist:  
[https://youtube.com/playlist?list=PLOQqEZQZuxkuJuUUSRPvX9GuainYzZoAU&si=JfoSud4r\\_CIEID2T](https://youtube.com/playlist?list=PLOQqEZQZuxkuJuUUSRPvX9GuainYzZoAU&si=JfoSud4r_CIEID2T)
2. Based on the key dates and local weather conditions, determine the best starting dates for you and make sure you can collect the bottle on the same day every week.

## Trap set-up:

3. Bring the **Malaise trap kit** and the **prepared week #1 bottle** (see Preparation Guide and Collection Guide) to the selected site.

4. Lay the trap tent flat on the ground with the white side facing up.



5. Assemble the short and long tent poles. Ensure each segment of the poles is securely fitted to each other.

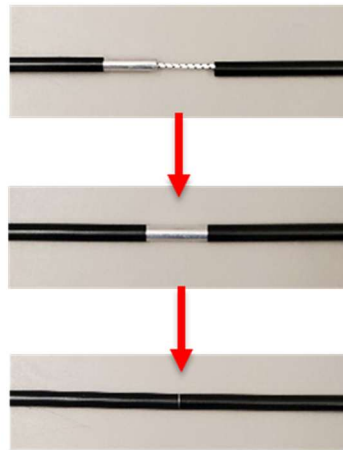

6. Start with the long tent pole and the tall trap head end of the trap. Insert the spring pins found at the bottom corners of the tent into the ends of the pole.

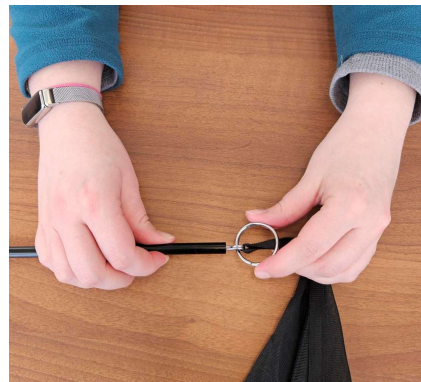
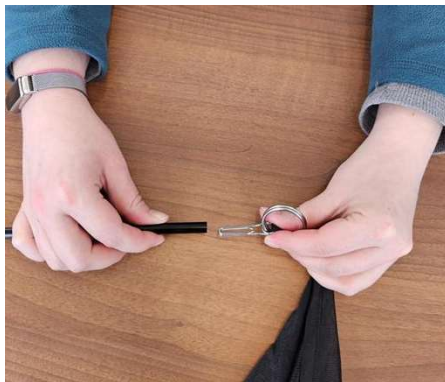

- Clip the hooks on the tent around the pole to form a mesh panel.



- Repeat steps 6 and 7 for the short end of the trap using the short tent pole.
  - With two people, stand up both the tall and short sides of the trap. Ensure that the trap head is over the long pole and fasten it with the white strap already attached to the tent.
- Quest Tip** – If you struggle with this step, you may stabilize the trap by staking the ends of the poles into the ground with the metal tent pegs. These can be adjusted later.
- Tie a support rope to the attachment point on the trap head and stake the other end of the rope into the ground with a metal tent peg.

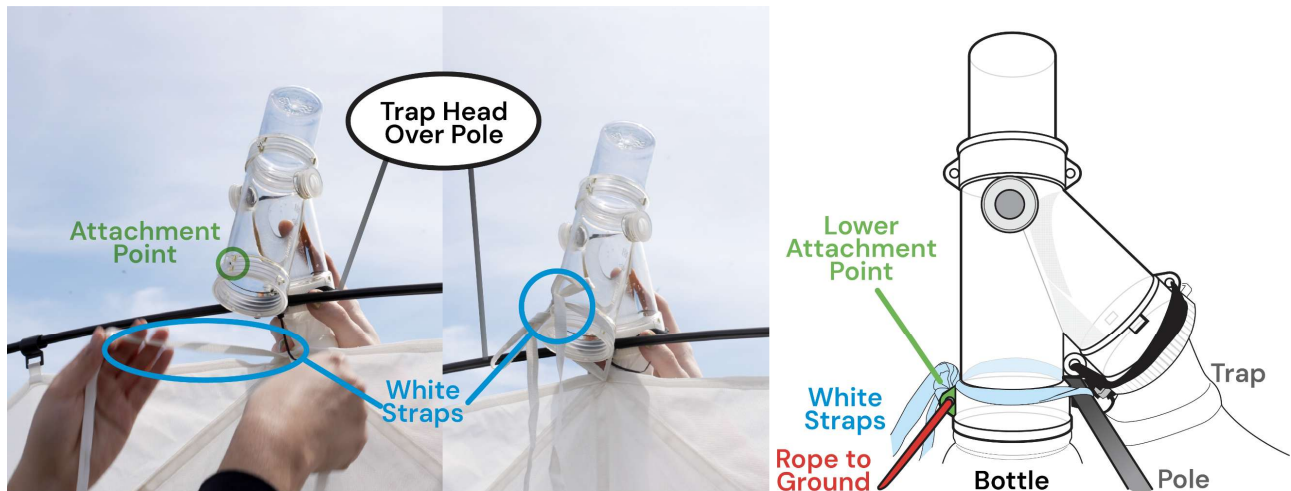

- At the short side of the trap, tie a support rope to the white tent loop and stake the other end of the rope into the ground.

12. Adjust the base of the trap so the trap body is fully stretched. Stake the trap to the ground using the metal tent pegs (8 pegs total), ensuring the 2 attachment points in the middle panel are also staked down. See images and diagram below.



13. Attach the remaining support ropes and adjust them to achieve proper trap shape and tension (8 ropes total). Secure the support ropes to the ground with the metal tent pegs.

See the diagram below: there are 3 support rope attachments at the short end (A, B, & C), 3 at the tall end (D, E, & F), and 1 on either side (G & H).

For the side support ropes, follow the white seam line along the trap roof to achieve the best shape.



**Quest Tip** – If there are trees nearby, tie the support ropes to them instead of using pegs.

### Top View of Malaise Trap

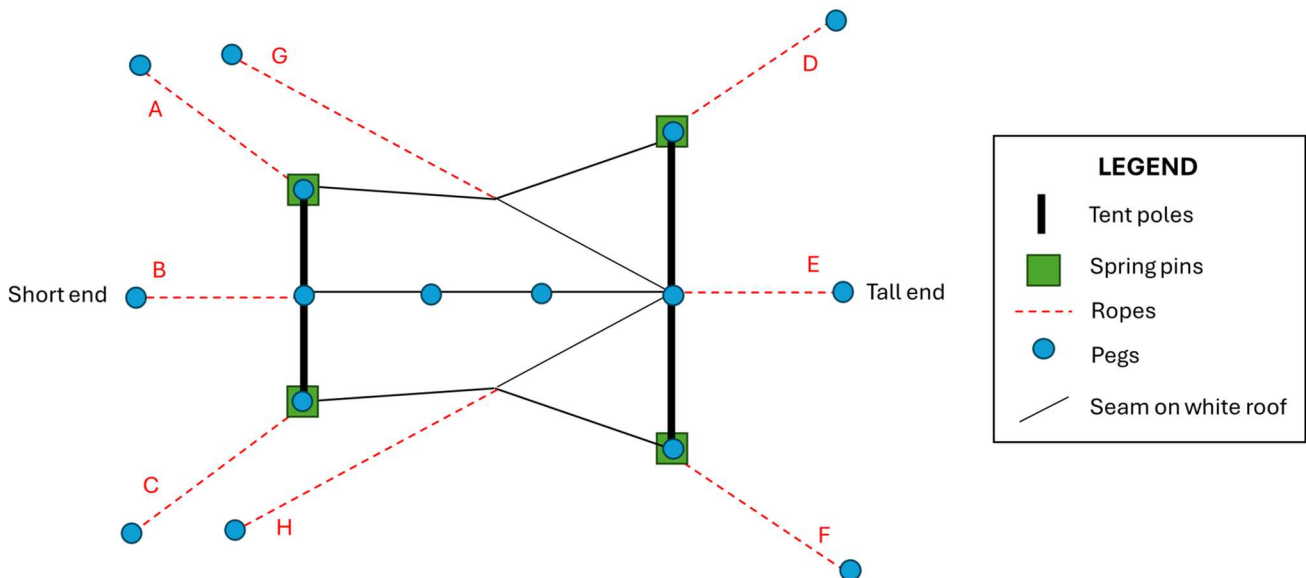

14. Attach flagging tape (provided) to each support rope to help prevent tripping.

💡 **Quest Tip** – If needed, place additional flagging tape around the entire trap area for visibility.

15. Once the trap is upright, attach the *BugQuest: Science in Progress* sign to the tall part of the trap (or a wall or stake) using the reusable cable ties, extra rope, or tape.

16. The Malaise trap is now set up! Take some pictures of your site and record the GPS coordinates and other site location details on the **Collection Log Sheet**. Photos and location details will be submitted through the **Digital Field Collection Form** at the end of the collection season.



17. Once your trap has been deployed, please take a few minutes to complete the short **BugQuest Trap Deployment Feedback Form**. This will help us improve the setup experience for future participants. Please ensure you have a photo of your trap and GPS coordinates handy.



💡 **Quest Tip** – Return to the trap the next day to make sure it is still standing properly and that flagging tape and signage are still attached. Adjust if needed.

Trap Deployment  
Feedback Form

18. Continue to the **Collection Guide** to attach the **week #1** bottle.

# Collection Guide

## What you'll need:

- Prepared collection bottle(s) – external and internal labels attached and filled with saltwater mixture
- Pencil
- Collection Log Sheet
- Freezer/Refrigerator
- Optional: collection bottle lid from previous week if already sampling

## Bottle collection:

1. Select **week #1 bottle**. Write the “**Start Date**” on both the **external sticker** and **internal paper labels** using a **PENCIL**.
2. Bring the week #1 bottle to the trap, take the lid off and save it for later. Then screw the bottle onto the bottom half of the trap head and tie it to the trap with the white straps. Review the trap set-up video if needed.



**Quest Tip** – Check the trap and the opening to the collection bottle **every other day** for damage, blockages, and after major weather events. Contact [bugquest.canada@gmail.com](mailto:bugquest.canada@gmail.com) if repairs or replacement parts are needed.

3. Return to the trap 1 week (7 days) later with the week #1 lid and next week's bottle. Make sure you go on the same day each week.
4. Carefully untie and unscrew the previous bottle and close it with the matching lid, then screw the next bottle (e.g., week #2, week #3, etc.) onto the bottom half of the trap head and tie it down with the white straps. Please ensure the coupling ring remains on the trap head and reattach if needed.

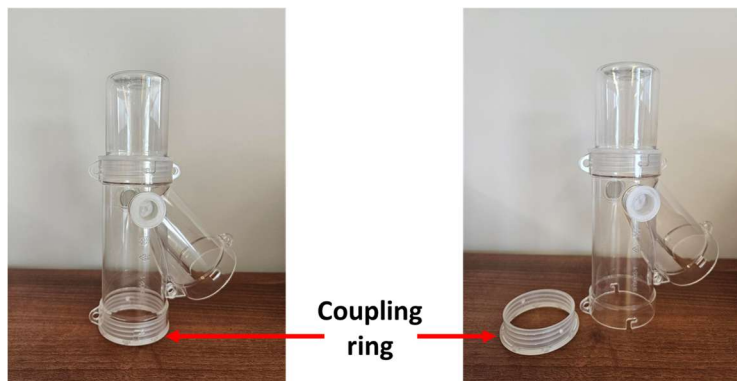

- On the completed bottle, write the “**End Date**” on both the **external sticker** and **internal paper labels** using a **PENCIL**. Tear off the internal paper label and place it inside the bottle with the insects.

 **Quest Tip** – In order to protect the insect DNA, please do not drain any water from your bottle or touch the specimens inside.

- Now record your observations. Use the **Collection Log Sheet** (and optional poster) to note any important details or any scientifically significant events (e.g. trap was down at collection, bottle was dry, weather information, trap disturbances, etc.).

**Example log sheet:**

Week # / Semaine n°	Bottle # / Bouteille n° (BQ#)	Start Date / Date de début (yyyy-mm-dd / aaaa-mm-jj)	End Date / Date de fin (yyyy-mm-dd / aaaa-mm-jj)	Notes / Remarques
1	BQ#00001	2026-09-14	2026-09-21	Light rain, repaired long pole
2				

The cold helps prevent the DNA from degrading, making it easier to extract.

- Store samples in a standard household freezer (e.g., -20°C) or refrigerator (e.g., 4°C).** Avoid exposure to heat, light, or changing temperatures. If freezer or refrigeration is not possible, contact [bugquest.canada@gmail.com](mailto:bugquest.canada@gmail.com) before making other arrangements.

- Repeat the above steps for the rest of the collection bottles.

 **Quest Tip** – If you’d like to continue sampling at your site and need additional supplies, contact [bugquest.canada@gmail.com](mailto:bugquest.canada@gmail.com) before collecting your last bottle to make arrangements.

- At the end of the collection season**, take your trap down, remove the *BugQuest: Science in Progress* sign and reusable cable ties, and store them with the rest of your Quest Kit. You may then pause until the next season or conclude your BugQuest participation, depending on your site timeline.

 **Quest Tip** – Make sure your trap is dry and remove any debris before packing it back into the bag.

**Next step: See the SHIPPING GUIDE for how to ship bottles back to the BugQuest Team!**

# Shipping Guide

## What you'll need:

- Return shipping label
- Return shipping label pouch
- BugQuest address sticker
- Shipping boxes/envelopes
- Large plastic bags
- Tape
- Completed collection bottles
- Completed Collection Log Sheet
- Paper towel (or other absorbent material)

## Shipping address:

Ross Stewart  
Centre for Biodiversity Genomics  
University of Guelph  
50 Stone Road East  
Guelph, ON  
Canada N1G 2W1  
+1 (519) 824-4120 ext. 58259

## Return shipping:

 **Quest Tip** – Bottles should be shipped back to the BugQuest Team as soon as you have: **4 bottles** (for envelope return shipping) OR **8 bottles** (for box return shipping)

1. Using your completed Collection Log Sheet, enter the details of the site(s) and bottles that you are shipping into **Digital Field Collection Form** — [https://bugquest.fillout.com/digital\\_collection\\_form](https://bugquest.fillout.com/digital_collection_form).



Digital Field Collection Form

2. Ensure the bottle lids are secured very tightly.
3. Pack the bottles with some paper towels into a large plastic bag (provided) and then seal the bag.
4. Place the sealed bag into another large plastic bag (provided) and seal.
5. Take a picture of your **Collection Log Sheet** for future reference and place the sheet and the packed bottles into a single shipping box (for a max of 8 bottles) or shipping envelope (for 4 or less bottles) for safe return shipping.
  - For Boxes: Close and seal securely with tape
  - For Envelopes: Fold over the envelope to limit excess space around the bottles and then close using the peel and stick seal on the envelope. If necessary, secure the seal with tape.



💡 **Quest Tip** – Prior to receiving your Quest Kit, you will have received an email confirming the creation of your return label. Printed return shipping labels are already provided for you in your Quest Kit. No additional printing is necessary. You may follow the links in the email to schedule a pickup and/or track your package once shipped.

6. Fold the prepaid Purolator return shipping label in half and place it in the pouch.
7. Remove the backing of the pouch and attach it and a BugQuest Address Sticker to the outside of the package.
8. Make sure you have filled out the **Digital Field Collection Form** and included your shipment details, especially the **Purolator Pin** number on your return shipping label. This will notify the BugQuest team that the package is on its way.



💡 **Quest Tip** – BugQuest bottles must be shipped within 8 weeks of collection to preserve DNA quality.

9. **Ship your package via Purolator:**
  - **Wherever possible, please drop off your package** at your nearest Purolator shipping location (<https://www.purolator.com/en/shipping/find-shipping-centre>). This will help us lower the costs so we can study more bugs!
  - If a pickup is required, go to <https://www.purolator.com/en/shipping/schedule-manage-pickup> and select “Schedule a Pickup” to arrange a pickup through the Purolator Virtual Assistant. Alternatively, you can arrange a pickup by calling 1-888-SHIP-123 (1-888- 744-7123).

💡 **Quest Tip** – Please send shipments out Monday-Wednesday, avoiding statutory holidays. This will help ensure bottles get back to the BugQuest Team as soon as possible so they can be correctly stored for DNA preservation.

#### Steps for using the Purolator Virtual Assistant:

1. Select “Schedule at my address”
2. You will be asked if your shipment is ready:
  - Select “Yes, it’s ready” to arrange same-day pickup OR “Select a future date or time”
3. Select “Within Canada”
4. Provide your phone number
5. Select “Schedule pickup as guest”
6. Select “Business” or “Residential”
  - “Business” → provide contact details and the name of your business
  - “Residential” → select “**Return**” → enter “Centre for Biodiversity Genomics”
7. Provide your contact information
8. Type in your address for pickup and confirm
9. Provide any relevant pickup details or instructions as prompted. You may select “skip” if not applicable.
10. Schedule pickup date and time:
  - If you selected “Yes, it’s ready,” select the latest time your package can be picked up by for the current day
  - If you selected “Select a future date or time,” choose the day and timeframe in which your package can be picked up

11. Provide the number and weight of your package:
  - Canada shipment pieces: 1
  - Canada shipment weight: Enter **9 lbs for 8 bottles** OR **4.5 lbs for 4 bottles**
12. Confirm your contact, pickup, and shipment information
13. Upon confirmation, you will be emailed a confirmation number – keep this for your record in case any modifications need to be made or issues arise.

 **Quest Tip** – If you encounter any shipping issues or are unable to ship with Purolator contact the BugQuest Team ([bugquest.canada@gmail.com](mailto:bugquest.canada@gmail.com)) to discuss alternative methods.

**Now that you have completed your part of the Quest, the BugQuest Team will be in touch to help you learn more about what you have discovered.**

**Results delivery.** Samples will be processed at the Centre for Biodiversity Genomics, and results will be emailed to participants in **2027**. Project reports will also be made available online on our website.